

OCM ECONOMICAL LINE

MX2 STEEL PINTLE CHAIN

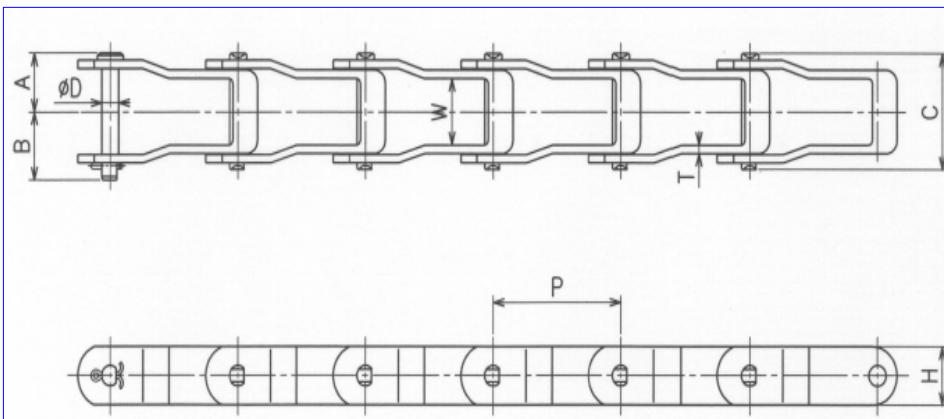

Chain No	Links in 1 meter or 10 feet	Weight kg per meter (lbs per 10 feet)	Average Ultimate Strength in kN/Lbs	Minimum Tensile Strength in kN/Lbs	P mm inch	A mm inch	B mm inch	C mm inch	D mm inch	H mm inch	W mm inch	T mm inch
667X	17.5 53	2.8 18.8	93.42 21000	66.7 15000	57.15 2.250	26.75 1.053	27.8 1.094	49.61 1.953	11.1 0.437	23.8 0.937	26.92 1.060	4.2 0.165
667XH	17.5 53	4.17 28	145 32600	124.5 28000	57.15 2.250	29.25 1.152	31.9 1.256	58 2.283	11.9 0.469	26.87 1.058	27.38 1.078	5.45 0.215
88K	15 46	3.4 22.8	110 24700	89 20000	66.27 2.609	28.82 1.135	31.3 1.232	53.9 2.122	11.1 0.437	26.84 1.057	27.38 1.078	5.08 0.200
88C	15 46	5.2 34.9	159 35700	133.45 30000	66.27 2.609	33.15 1.305	38.8 1.528	63.5 2.500	12.7 0.500	28.58 1.125	31.73 1.249	6.35 0.250

Many other sizes are available. CA550 is available.