

APRON CONVEYOR CHAIN

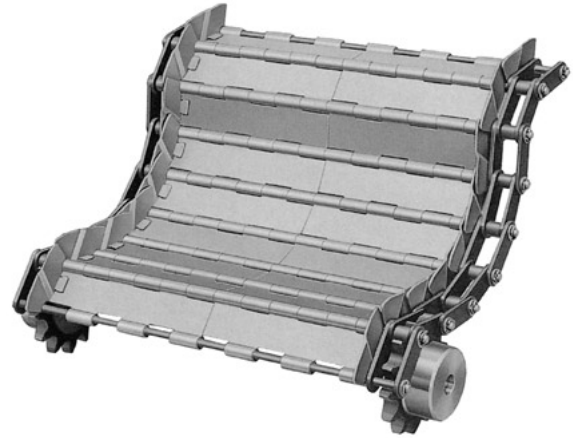
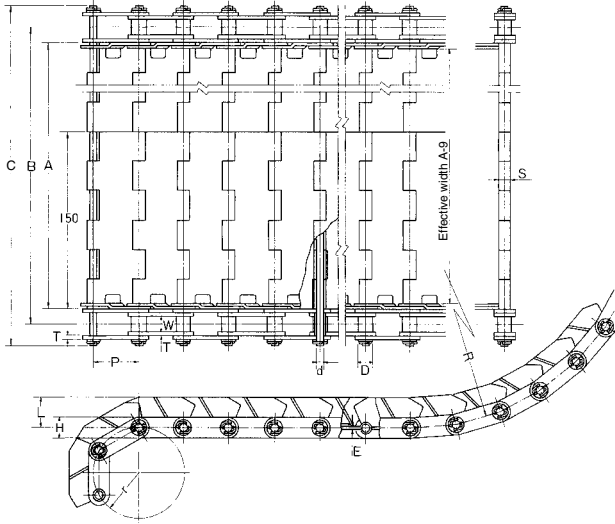

UNIT:mm

OCM Chain No.	A	B	C	L height/ thickness	Hinge thickness	E	S	Side Chain					Min. Upturn Radius	Min. Downturn Radius	Allowable load		Weight	
								OCM Chain No.	Pitch	Roller Diam.	Width between L.P.	Link Plate			Pin Diam.	kN		kgf
								P	D	W	H	T	d	R	r			kg/m
EC2060H-150	150	176.4	214.2					38.1	*11.91	12.7	17.2	3.2	5.95	200	38.1	8.82	900	8.0
EC2060H-300	300	326.4	364.2	25/2.0	2	10.4	C2060H											13.8

Note: 1) * 22.23 diameter is available.
 2) A dimension wider than 150 and 300 is available.
 3) EC2080H is also available.

CURVE (SIDE BOW) CONVEYOR CHAIN

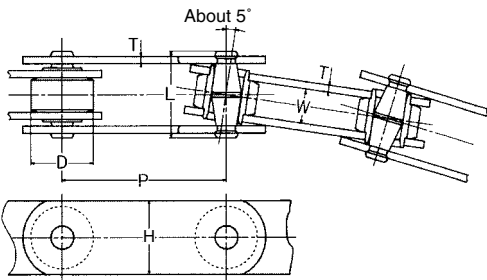

TYPE CL

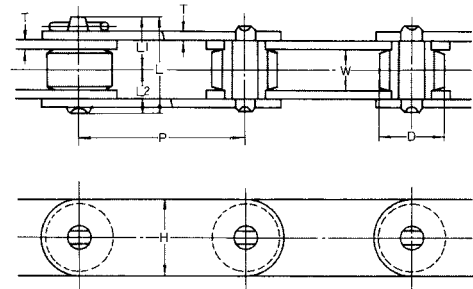

TYPE SL

UNIT:mm

OCM Chain No.	Pitch	Roller Diam.	Width between L.P.	Link Plate		Pin			Sideflex Radius		Average breaking load		Allowable load		Weight
									Min	Ordinary use	kN	kgf	kN	kgf	
	P	D	W	H	T	L	L1	L2							kg/m
CL 80	80	38	21	45	4.5	52	-	-	650	800	49.02	5000	6.68	700	5.8
CL 100	100	38	21	45	4.5	52	-	-	750	900	49.02	5000	6.68	700	6.5
SL 100	100	38	21	45	4.5	50	27	23	-	-	68.63	7000	9.80	1000	6.0