

STRAIGHT LINK PLATE CHAIN

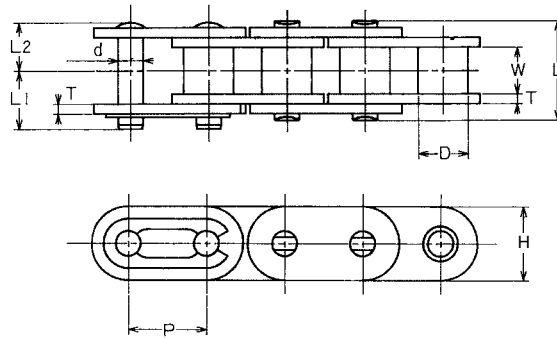

UNIT Upper:inch
Beneath:mm

OCM Chain No.	Pitch	Roller Diam.	Width between L.P.	Link Plate		Pin Diam.	Pin			Average Tensile Strength	Allowable Load	Approx Weight
	P	D	W	H	T	d	L	L1	L2	Lb/kgf	Lb/kgf	Lb/ft kg/m
40E	0.500	0.312	0.313	0.472	0.059	0.156	0.634	0.382	0.317	4299	904	0.47
	12.7	7.92	7.95	12	1.5	3.96	16.1	9.7	8.05	1950	410	0.7
50E	0.625	0.4	0.376	0.591	0.079	0.2	0.799	0.476	0.4	7165	1455	0.76
	15.875	10.16	9.55	15	2	5.08	20.3	12.1	10.15	3250	660	1.13
60E	0.750	0.469	0.5	0.709	0.094	0.234	1	0.579	0.5	9921	2205	1.09
	19.05	11.91	12.7	18	2.4	5.95	25.4	14.7	12.7	4500	1000	1.62
80E	1.000	0.625	0.626	0.945	0.126	0.313	1.287	0.76	0.644	17637	3638	2.02
	25.4	15.88	15.9	24	3.2	7.94	32.7	19.3	16.35	8000	1650	3
100E	1.250	0.75	0.754	1.181	0.157	0.375	1.571	0.925	0.787	26455	5512	3.16
	31.75	19.05	19.15	30	4	9.53	39.9	23.5	20	12000	2500	4.7
120E	1.500	0.875	1.006	1.425	0.189	0.437	1.972	1.118	0.988	37038	7275	4.66
	38.1	22.23	25.55	36.2	4.8	11.11	50.1	28.4	25.1	16800	3300	6.93

Offset link is not available.
Duplex, nickel plated and stainless steel are available.

DEEP LINK PLATE CHAIN

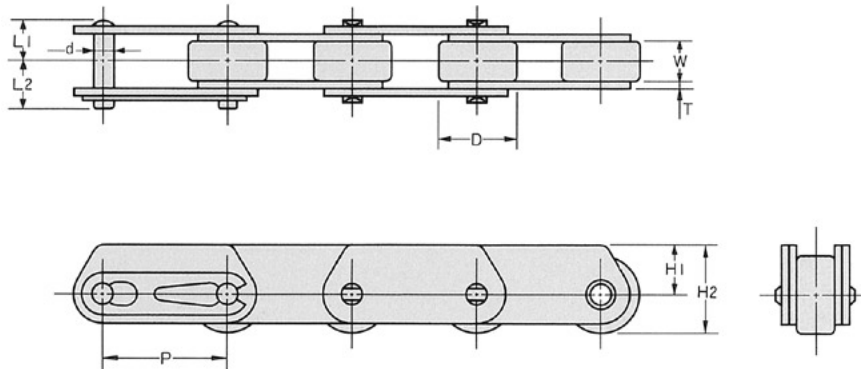

UNIT Upper:inch
Beneath:mm

OCM Chain No.	Pitch	Roller Diam.	Width between L.P.	Link Plate			Pin Diam.	Pin		Average Tensile Strength	Allowable Load
	P	D	W	H1	H2	T	d	L1	L2	Lb/kgf	Lb/kgf
C2042	1.000	0.625	0.313	0.394	0.705	0.059	0.156	0.315	0.382	3638	595
	25.4	15.88	7.95	10	17.9	1.5	3.96	8	9.7	1650	270
C2052	1.250	0.75	0.376	0.472	0.846	0.079	0.2	0.409	0.476	5952	970
	31.75	19.05	9.55	12	21.5	2	5.08	10.4	12.1	2700	440
C2062H	1.500	0.875	0.5	0.551	0.988	0.126	0.234	0.571	0.661	8598	1323
	38.1	22.23	12.7	14	25.1	3.2	5.95	14.5	16.8	3900	600
C2082H	2.000	1.125	0.626	0.709	1.268	0.157	0.313	0.709	0.839	14771	2205
	50.8	28.58	15.9	18	32.2	4	7.94	18	21.3	6700	1000