

# WIDE CHAIN WITH CROSSRODS

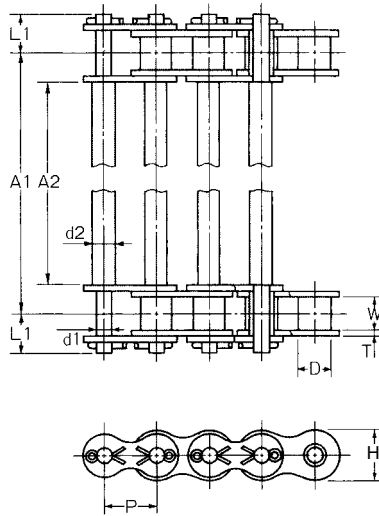

UNIT Upper:inch  
Beneath:mm

OCM Chain No.	Pitch P	Roller Diam. D		Width between L.P. W		Link Plate		Pin		Bar A1,A2
						H	T	d1	L1	
40	0.500	0.313	0.313	0.313	0.472	0.059	0.156	0.402	0.244	Specify either A1 or A2
	12.7	7.94	7.95	7.95	12	1.5	3.96	10.2	6.2	
50	0.625	0.4	0.376	0.591	0.079	0.2	0.476	0.276	Specify either A1 or A2	
	15.875	10.16	9.55	9.55	15	2	5.08	12.1		
60	0.750	0.469	0.5	0.709	0.094	0.234	0.598	0.319		Specify either A1 or A2
	19.05	11.91	12.7	12.7	18	2.4	5.95	15.2		
80	1.000	0.625	0.626	0.945	0.126	0.313	0.776	0.381	Specify either A1 or A2	
	25.4	15.88	15.9	15.9	24	3.2	7.94	19.7		

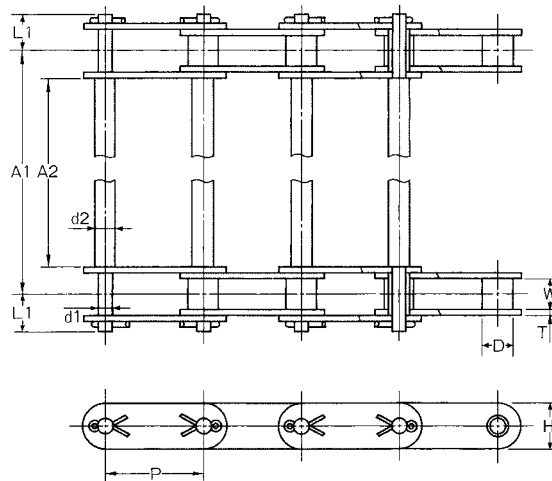

UNIT Upper:inch  
Beneath:mm

OCM Chain No.	Pitch P	Roller Diam. D		Width between L.P. W	Link Plate		Pin		Bar		
		Small Roller	Large Roller		H	T	d1	L1	d2	A1,A2	
C2040-C2042	1.000	0.313	0.625	0.313	0.472	0.059	0.156	0.402	0.244	Specify either A1 or A2	
	25.4	7.94	15.88	7.95	12	1.5	3.96	10.2	6.2		
C2050-C2052	1.250	0.4	0.75	0.376	0.591	0.079	0.2	0.476	0.276		Specify either A1 or A2
	31.75	10.16	19.05	9.55	15	2	5.08	12.1	7		
C2060H-2062H	1.500	0.469	0.875	0.5	0.677	0.126	0.234	0.661	0.319	Specify either A1 or A2	
	38.1	11.91	22.23	12.7	17.2	3.2	5.95	16.8	8.09		
C2080H-C2082H	2.000	0.625	1.125	0.626	0.945	0.157	0.313	0.839	0.381		Specify either A1 or A2
	50.8	15.88	28.58	15.9	24	4	7.94	21.3	9.68		