

BS/DIN STAINLESS ROLLER CHAIN

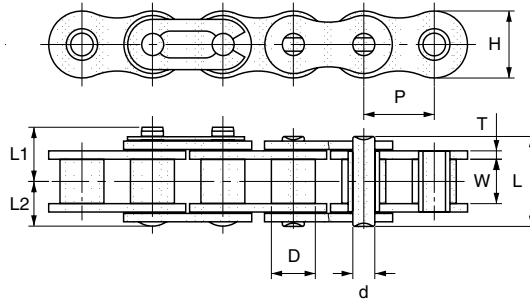

Material: 304 stainless steel
UNIT:mm

OCM Chain No.	Pitch	Width between L.P.	Link Plate	Roller Diam.	Link Plate	Pin Diam.	Pin			Max Working Load	Approx Weight
	P	W	H	D	T	d	L	L1	L2		
04	6.00	2.80	4.90	4.00	0.60	1.85	7.35	-	-	6/0.06	0.11
05B	8.00	7.80	7.10	5.00	0.75	2.30	7.80	-	-	12/0.12	0.18
06B	9.525	5.72	8.20	6.35	1.27/1.0	3.28	13.75	7.25	6.50	27/0.26	0.39
08B	12.70	7.75	12.00	8.51	1.50	4.45	18.40	10.05	8.35	45/0.44	0.55
10B	15.875	9.65	14.70	10.16	1.50	5.08	19.10	11.25	9.55	70/0.70	0.94
12B	19.05	11.68	16.10	12.07	1.8/1.7	5.72	22.20	13.00	11.10	105/1.00	1.25
16B	25.40	17.02	20.30	15.88	4.0/3.2	8.26	35.10	20.60	17.60	210/2.06	2.59

Connecting link for 16B is cotter. 06B is straight link plate.

BS/DIN NICKEL PLATED ROLLER CHAIN

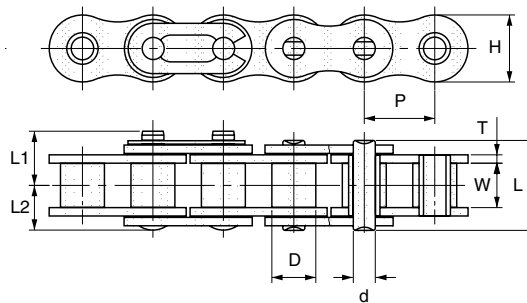

UNIT:mm

OCM Chain No.	ISO-B No.	Pitch	Roller Diam.	Width between L.P.	Link Plate			Pin Diam.	Pin				Minimum Tensile strength	Approx Weight
		P	D	W	H	T	t	d	L	L3	L1	L2		
04	-	6.00	4.00	2.80	5.00	0.60	0.60	1.85	7.30	3.10	-	-	310	0.12
05B	05B	8.00	5.00	3.20	7.10	0.75	0.75	2.30	8.70	3.90	-	-	470	0.18
06B	06B	9.525	6.35	5.72	8.20	1.32	1.05	3.28	13.40	7.20	7.60	6.60	910	0.37
08B	08B	12.70	8.51	7.85	11.80	1.62	1.62	4.45	18.30	9.80	10.60	8.50	1820	0.71
10B	10B	15.875	10.16	9.80	14.70	1.62	1.62	5.08	21.20	11.60	11.70	9.70	2270	0.95
12B	12B	19.05	12.07	11.70	16.10	1.88	1.88	5.72	24.30	13.10	13.60	11.30	2950	1.30
16B	16B	25.40	15.88	17.05	21.08	4.10	3.20	8.28	38.20	20.20	21.70	20.20	6500	2.90
20B	20B	31.75	19.02	19.60	26.00	4.40	3.50	10.16	43.85	23.70	25.15	23.00	10000	3.80
24B	24B	38.10	25.4	25.40	33.40	5.90	4.90	14.61	58.75	32.00	32.45	30.70	17000	7.10
28B	28B	44.45	27.94	31.00	36.70	7.40	6.30	15.88	70.45	37.70	39.10	36.30	20400	8.60
32B	32B	50.80	29.21	31.00	41.90	6.90	6.30	17.79	71.10	37.70	39.50	36.60	26000	9.60

t is pin link plate thickness.