

WIDE CHAIN WITH CROSSRODS

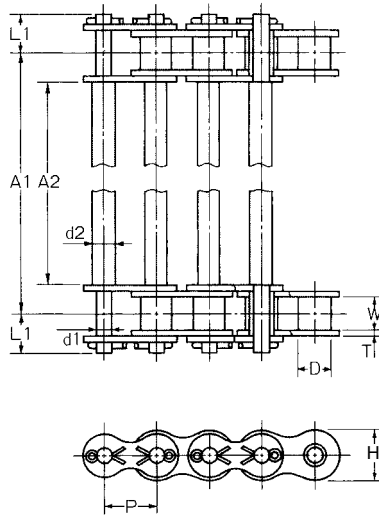

UNIT Upper:inch
Beneath:mm

OCM Chain No.	Pitch	Roller Diam.	Width between L.P.	Link Plate		Pin		d2	Bar A1,A2
	P	D	W	H	T	d1	L1		
40	0.500	0.313	0.313	0.472	0.059	0.156	0.402	0.244	Specify either A1 or A2
	12.7	7.94	7.95	12	1.5	3.96	10.2	6.2	
50	0.625	0.4	0.376	0.591	0.079	0.2	0.476	0.276	
	15.875	10.16	9.55	15	2	5.08	12.1	7	
60	0.750	0.469	0.5	0.709	0.094	0.234	0.598	0.319	
	19.05	11.91	12.7	18	2.4	5.95	15.2	8.09	
80	1.000	0.625	0.626	0.945	0.126	0.313	0.776	0.381	
	25.4	15.88	15.9	24	3.2	7.94	19.7	9.68	

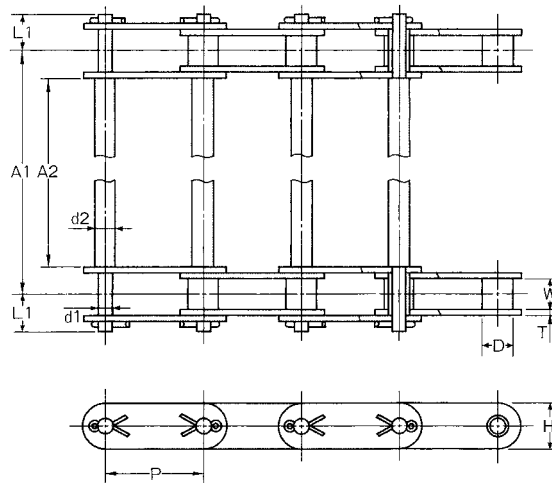

UNIT Upper:inch
Beneath:mm

OCM Chain No.	Pitch	Roller Diam. D		Width between L.P.	Link Plate		Pin		Bar	
	P	Small Roller	Large Roller	W	H	T	d1	L1	d2	A1,A2
C2040-C2042	1.000	0.313	0.625	0.313	0.472	0.059	0.156	0.402	0.244	Specify either A1 or A2
	25.4	7.94	15.88	7.95	12	1.5	3.96	10.2	6.2	
C2050-C2052	1.250	0.4	0.75	0.376	0.591	0.079	0.2	0.476	0.276	
	31.75	10.16	19.05	9.55	15	2	5.08	12.1	7	
C2060H-2062H	1.500	0.469	0.875	0.5	0.677	0.126	0.234	0.661	0.319	
	38.1	11.91	22.23	12.7	17.2	3.2	5.95	16.8	8.09	
C2080H-C2082H	2.000	0.625	1.125	0.626	0.945	0.157	0.313	0.839	0.381	
	50.8	15.88	28.58	15.9	24	4	7.94	21.3	9.68	