

### Support Roller

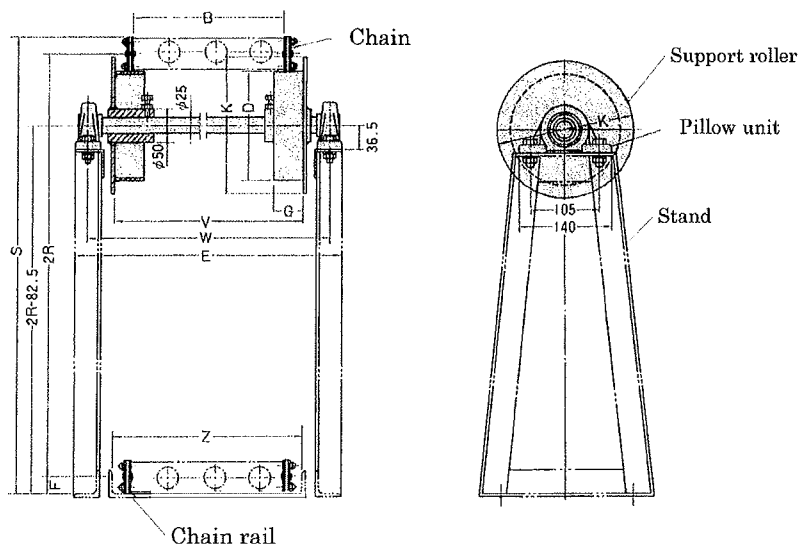

### Support roller dimension (Reference)

Radius is minimum chain bending radius.

UNIT: mm

Chain No	B	V	W	E	RADIUS	F	S	D	G	K	Z
	Min.				Min.						
N-KCS70	100	B+55	B+125	B+163	75	25	2R+50	165	50	205	B+50
N-KCS100	100	B+60	B+135	B+168	125	35	2R+70	165	50	205	B+55
N-KCS130	100	B+75	B+145	B+183	200	48	2R+96	165	60	285	B+70
N-KCS180	125	B+85	B+155	B+193	250	70	2R+140	165	60	285	B+80