

DEEP LINK PLATE CONVEYOR CHAIN

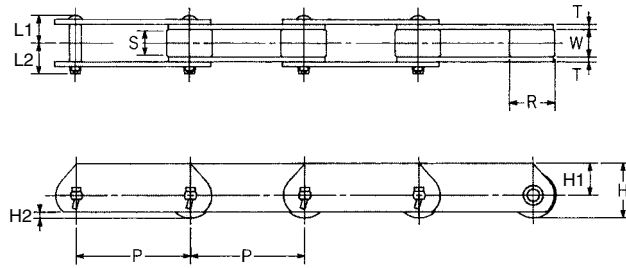

UNIT:mm

| OCM Chain No. | Pitch P | R | S | Width between L.P. W | Link Plate | | | | Pin | | Weight kg/m | Allowable roller load | | | | Average Breaking Load | | | | |
|---------------|---------|------|------|----------------------|------------|----|------|-----|------|------|-------------|-----------------------|-------|------------|-------|-----------------------|-------|------------|-------|--|
| | | | | | H | H1 | H2 | T | L1 | L2 | | Standard | | Heavy Duty | | Standard | | Heavy Duty | | |
| | P | R | S | W | H | H1 | H2 | T | L1 | L2 | kg/m | kN/pc | kg/pc | kN/pc | kg/pc | kN | kgf | kN | kgf | |
| FMD 3075R | 75 | | | | | | | | | | 3.2 | | | | | | | | | |
| FMD 3100R | 100 | 30 | 15.5 | 18 | 36 | 21 | 4 | 3.2 | 18 | 20 | 2.8 | 0.59 | 60 | 0.88 | 90 | 29.41 | 3000 | 60.78 | 6200 | |
| FMD 5100R | 100 | | | | | | | | | | 5.9 | | | | | | | | | |
| FMD 5150R | 150 | 40 | 19 | 22.2 | 44 | 24 | 4 | 4.5 | 24 | 27 | 4.9 | 0.93 | 95 | 1.47 | 150 | 68.63 | 7000 | 138.24 | 14100 | |
| FMD10150R | 150 | | | | | | | | | | 9.7 | | | | | | | | | |
| FMD10200R | 200 | 50 | 26.5 | 30 | 57 | 32 | 6.4 | 6.3 | 32 | 36 | 8.5 | 1.57 | 160 | 2.6 | 265 | 112.75 | 11500 | 225.49 | 23000 | |
| FED12600R | 152.4 | 57.2 | 31.5 | 36.5 | 63.6 | 35 | 6.1 | 7.9 | 40 | 46 | 14 | 2.11 | 215 | 3.53 | 360 | 186.27 | 19000 | 277.45 | 28000 | |
| FMD12200R | 200 | | | | | | | | | | 14.9 | | | | | | | | | |
| FMD12250R | 250 | 65 | 32 | 36.5 | 73.5 | 41 | 10 | 7.9 | 39.5 | 46 | 13.5 | 2.45 | 250 | 4.12 | 420 | 186.27 | 19000 | 277.45 | 28000 | |
| FMD17250R | 250 | | | | | | | | | | 22.5 | | | | | | | | | |
| FMD17300R | 300 | 80 | 45.8 | 50.8 | 90 | 50 | 13.8 | 9.5 | 51 | 59.5 | 21.5 | 4.31 | 440 | 7.16 | 730 | 245.1 | 25000 | 392.16 | 40000 | |

OUTBOARD CONVEYOR CHAIN

Base chain is FM type S roller conveyor chain with flange outboard roller. When ordering, please specify the spacing of outboard roller.

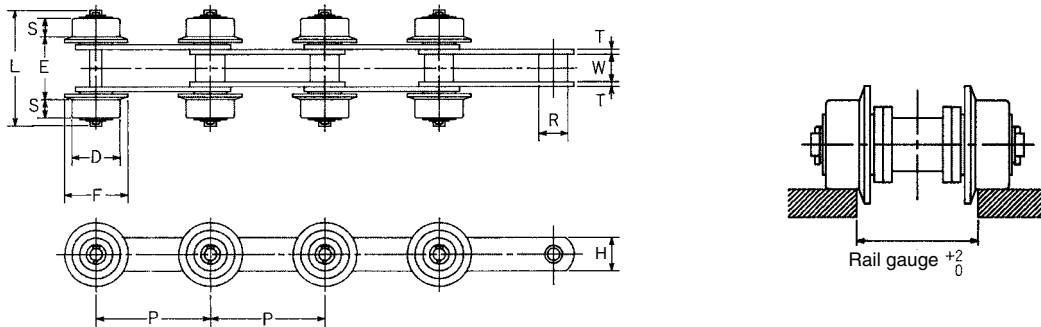

UNIT:mm

| OCM Chain No. | Pitch P | R | Width between L.P. W | Link Plate | | Outboard Roller | | | Pin | | Rail gauge | *See below kg | Allowable outboard roller(both sides) | | | |
|---------------|---------|-------|----------------------|------------|-----|-----------------|----|----|-------|-------|------------|---------------|---------------------------------------|-----|--------------|-----|
| | | | | H | T | D | F | S | L | E | | | Not Heat treated | | Heat treated | |
| | P | R | W | H | T | D | F | S | L | E | kg | kN | kgf | kN | kgf | |
| FM 3075-S-SR | 75 | | | | | | | | | | | | | | | |
| FM 3100-S-SR | 100 | 19.05 | 18 | 22 | 3.2 | 31.8 | 42 | 12 | 74 | 38 | 40 | 0.3 | 0.69 | 70 | 1.08 | 110 |
| FM 5075-S-SR | 75 | | | | | | | | | | | | | | | |
| FM 5100-S-SR | 100 | 22.2 | 22.2 | 32 | 4.5 | 40 | 50 | 14 | 102 | 55 | 57 | 0.5 | 1.18 | 120 | 1.86 | 190 |
| FM 5150-S-SR | 150 | | | | | | | | | | | | | | | |
| FM10100-S-SR | 100 | | | | | | | | | | | | | | | |
| FM10150-S-SR | 150 | 30 | 30 | 38 | 6.3 | 50 | 65 | 20 | 135.6 | 73 | 75 | 1 | 1.86 | 190 | 3.13 | 320 |
| FM12200-S-SR | 200 | | | | | | | | | | | | | | | |
| FM12250-S-SR | 250 | 34.93 | 36.5 | 45 | 7.9 | 65 | 85 | 24 | 165 | 92.5 | 94.5 | 1.8 | 2.94 | 300 | 4.8 | 490 |
| FM17200-S-SR | 200 | | | | | | | | | | | | | | | |
| FM17250-S-SR | 250 | 40.1 | 50.8 | 50.8 | 9.5 | 65 | 85 | 24 | 186 | 111.4 | 113.4 | 3.8 | 3.04 | 310 | 5.1 | 520 |
| FM17300-S-SR | 300 | | | | | | | | | | | | | | | |

Note: * Additional weight of one pair of outboard rollers.