

TOP ROLLER CHAIN

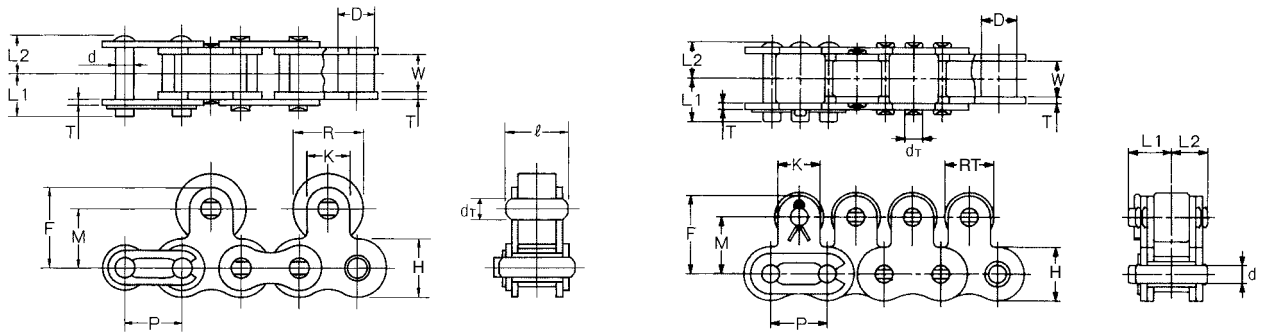

UNIT Upper:inch
Beneath:mm

OCM Chain No.	Pitch P	Roller Diam. D	Width between L.P. W		Link Plate H T		Pin Diam. d	Pin L1 L2		Pin R RT		Attachment ℓ F K M dr					Average Tensile Strength Lb/kgf	Allowable Load Lb/kgf	Approx Weight every 2nd link every link	
			Small	Large	Small	Large		Small	Large	Small	Large	Small	Large	Small	Large	Lb/ft			kg/m	
40	0.500	0.312	0.313	0.472	0.059	0.156	0.382	0.319	0.625	0.433	0.504	0.687	0.374	0.5	0.156	3638	617	0.81	1.08	
	12.7	7.92	7.95	12	1.5	3.96	9.7	8.1	15.88	11	12.8	17.45	9.5	12.7	3.96	1650	280	1.2	1.6	
50	0.625	0.4	0.376	0.591	0.079	0.2	0.476	0.409	0.75	0.591	0.626	0.876	0.5	0.626	0.2	5952	1014	1.21	1.34	
	15.875	10.16	9.55	15	2	5.08	12.1	10.4	19.05	15	15.9	22.25	12.7	15.9	5.08	2700	460	1.8	2	
60	0.750	0.469	0.5	0.709	0.094	0.234	0.579	0.5	0.875	0.709	0.799	1.033	0.626	0.72	0.233	8333	1411	1.88	2.15	
	19.05	11.91	12.7	18	2.4	5.95	14.7	12.7	22.23	18	20.3	26.25	15.9	18.3	5.93	3780	640	2.8	3.2	
80	1.000	0.625	0.626	0.945	0.126	0.313	0.74	0.642	1.125	0.945	1.043	1.344	0.752	0.969	0.313	14110	2359	3.09	3.56	
	25.4	15.88	15.9	24	3.2	7.94	18.8	16.3	28.58	24	26.5	34.15	19.1	24.6	7.94	6400	1070	4.6	5.3	
100	1.250	0.75	0.754	1.181	0.157	0.375	0.925	0.787	1.563	0.787	1.24	1.752	1	1.252	0.375	20613	3461	5.17	5.44	
	31.75	19.05	19.15	30	4	9.53	23.5	20	39.69	20	31.5	44.5	25.4	31.8	9.53	9350	1570	7.7	8.1	

Top roller is heat treated. Top roller of poly acetal is available. Supplied on a made to order basis.

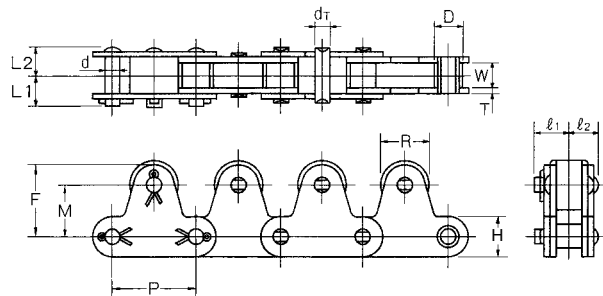

UNIT Upper:inch
Beneath:mm

OCM Chain No.	Pitch P	Roller Diam. D		Width between L.P. W	Link Plate H T		Pin d L1 L2		Pin R F M		Attachment dr ℓ1 ℓ2				Average Tensile Strength Lb/kgf	Allowable Load Lb/kgf	Approx Weight Small Roller Large Roller		
		Small Roller	Large Roller		Small	Large	Small	Large	Small	Large	Small	Large	Lb/ft	kg/m					
C2040-C2042	1.000	0.312	0.625	0.313	0.472	0.059	0.156	0.382	0.319	0.625	0.827	0.591	0.200	0.411	0.329	3638	617	0.89	1.14
	25.4	7.92	15.88	7.95	12	1.5	3.96	9.7	8.1	15.88	21	15	5.08	10.45	8.35	1650	280	1.33	1.69
C2050-C2052	1.250	0.400	0.750	0.376	0.591	0.079	0.200	0.476	0.409	0.750	1.043	0.748	0.233	0.508	0.409	5952	1014	1.37	1.68
	31.75	10.16	19.05	9.55	15	2	5.08	12.1	10.4	19.05	26.5	19	5.93	12.9	10.4	2700	460	2.04	2.5
C2060H-C2062H	1.500	0.469	0.875	0.500	0.677	0.126	0.234	0.650	0.563	0.875	1.244	0.906	0.319	0.713	0.583	8598	1411	2.47	2.93
	38.1	11.91	22.23	12.7	17.2	3.2	5.95	16.5	14.3	22.23	31.6	23	8.09	18.1	14.8	3900	640	3.68	4.36
C2080H-C2082H	2.000	0.625	1.125	0.626	0.945	0.157	0.313	0.839	0.709	1.125	1.594	1.142	0.375	0.866	0.720	14771	2359	3.8	4.54
	50.8	15.88	28.58	15.9	24	4	7.94	21.3	18	28.58	40.5	29	9.53	22	18.3	6700	1070	5.65	6.76
C2100H-C2102H	2.500	0.750	1.563	0.754	1.142	0.189	0.375	0.992	0.850	1.563	1.957	1.394	0.437	0.992	0.862	23149	3461	6.12	7.64
	63.5	19.05	39.69	19.15	29	4.8	9.53	25.2	21.6	39.69	49.7	35.4	11.11	25.2	21.9	10500	1570	9.11	11.37

Weight is for top roller every link. Special sprockets are required for large roller chain. Supplied on a made to order basis.