

WIDE CONTOUR ATTACHMENT

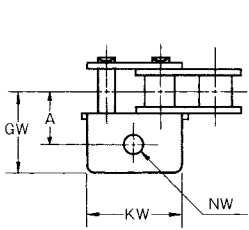

TYPE WA-1

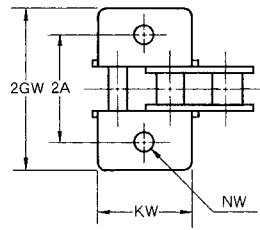

TYPE WK-1

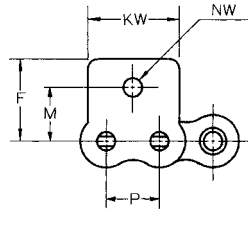

TYPE WSA-1

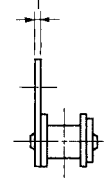

TYPE WSK-1

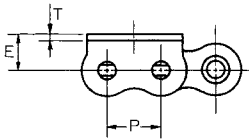

TYPE WA-2

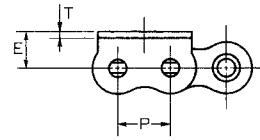

TYPE WK-2

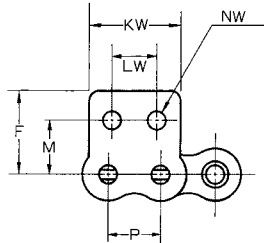

TYPE WSA-2

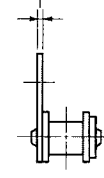

TYPE WSK-2

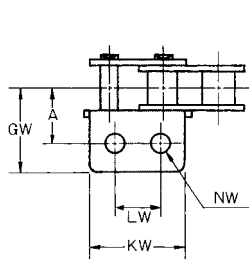

TYPE WA-2

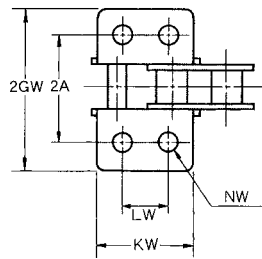

TYPE WK-2

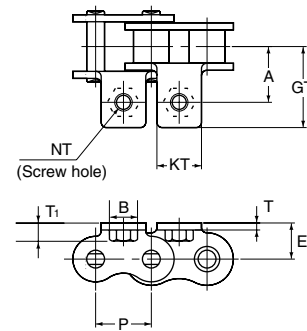

TYPE PA-1

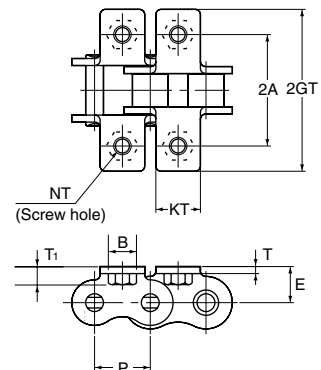

TYPE PK-1

UNIT Upper:inch
Beneath:mm

OCM Chain No.	Pitch P															Link Plate T	Additional Weight Per Attachment Lb/kgf			
		KW	KT	LW	NW	NT	A	E	GW	GT	B	T1	M	F	TA		TK	WA, WSA	WK, WSK	
40	0.500	0.906	0.374	0.374	0.177		0.500	0.315	0.691	0.691	0.319	0.150	0.500	0.689	0.059	0.002	0.004	0.009	0.018	
	12.7	23	9.5	9.5	4.5	M4	12.7	8	17.55	17.55	8.1	3.8	12.7	17.5	1.5	0.001	0.002	0.004	0.008	
50	0.625	1.134	0.500	0.469	0.217		0.626	0.406	0.909	0.909	0.362	0.201	0.626	0.909	0.079	0.009	0.018	0.015	0.031	
	15.875	28.8	12.7	11.9	5.5	M5	15.9	10.3	23.1	23.1	9.2	5.1	15.9	23.1	2	0.004	0.008	0.007	0.014	
60	0.750	1.362	0.626	0.563	0.260		0.750	0.469	1.094	1.094	0.453	0.287	0.720	1.057	0.094	0.015	0.031	0.029	0.057	
	19.05	34.6	15.9	14.3	6.6	M6	19.05	11.9	27.8	27.8	11.5	7.3	18.3	26.85	2.4	0.007	0.014	0.013	0.026	
80	1.000	1.815	0.752	0.752	0.354		1.000	0.626	1.402	1.276	0.591	0.339	0.969	1.366	0.126	0.024	0.049	0.062	0.123	
	25.4	46.1	19.1	19.1	9	M8	25.4	15.9	35.6	32.4	15	8.6	24.6	34.7	3.2	0.011	0.022	0.028	0.056	